

Proposed amendment to GCU APPENDIX 9

Record of amendments

Amended by	Date	Paragraph	Amendment
Jean-Marc Blondé	20/03/2019		See minutes of TTI WG meeting of October 2019
Lukas Halbig	03/03/2020		See minutes of TTI WG meeting of January 2020
TTI WG decision	24/03/2020		See minutes of TTI WG meeting of March 2020
Approved by SG WU	26/05/2020		See minutes of WU SG meeting of May 2020
Approved by JC GCU	15/06/2020		

Title:	Amendment of codes 1.4.1 and 1.4.2 in accordance with EN-15313 2016
Proposed amendment made by: RU / keeper / other body	Prepared by DB Cargo AG/SBB Cargo AG
Proposed amendment concerns:	<input checked="" type="checkbox"/> Appendix 9 <input type="checkbox"/> Appendix 11
Proposer:	Jean-Marc Blondé
Location, date:	Olten, 20/01/2020
Concise description:	<p>A limit of 36.0 mm is specified in the provisions of the GCU for the height of the wheel flange. A limit of 27.5 to 32.0 mm is specified in the Usage Guidelines for Composite Brake Blocks (tenth edition) applicable to the use of LL brake blocks on freight wagons with a maximum speed greater than 100 km/h.</p> <p>Verification of maximum thickness of flanges is introduced for LL and K disc braked vehicles.</p>

1. Starting point (current situation):

1.1. Introduction
No limit is defined for the height of the flange for the case of LL brake blocks and speeds > 100 km/h in the current provisions of GCU 1.4.1. The text makes reference to the general size limit of 36.0 mm. Furthermore, for wheelsets with composite brake blocks, account is not taken of the fact that thicker wheel flanges may be possible, i.e. above $S_d = 33$ mm.
1.2. Mode of operation
-
1.3. Anomaly / description of problem
The contents of the Usage Guidelines for Composite (LL) Brake Blocks (tenth edition), Part 2: Brake operation, monitoring and maintenance, and the Design Rules for Composite (LL) Brake Blocks (ninth edition) are not implemented in full in Appendix 1, Annex 9 of the GCU.

1.4. Does this concern a recognised code of practice* (e.g. DIN, EN)?
<input type="checkbox"/> No <input checked="" type="checkbox"/> Yes (state which): EN-15313/2016
<small>* "Code of practice: a written set of rules that, when correctly applied, can be used to control one or more specific hazards." (source: Regulation EC 352/2009, Article 3) "Technical provisions laid down in writing or conveyed verbally and pertaining to procedures, equipment and modes of operation which are generally agreed by the populations concerned (specialists, users, consumer and public authorities) to be suitable for achieving the objective prescribed by law, and which have either proven their worth in practice or, it is generally agreed, are likely to within a reasonable period of time" (translation/source: BMJ Handbuch der Rechtsförmlichkeit – German Ministry of Justice)</small>

2. Target situation

2.1. Elimination of anomaly/problem (goal)
Inclusion of a maximum dimension of 32.0 mm for wheels on vehicles braked with LL blocks and a maximum dimension of 33.0 mm for wheels on vehicles braked in LL and K.

3. Additional text and/or change relates only to proposed amendments to GCU Appendix 9:

Amendment colour code:

Black: Current text, for info and remains unchanged

Red: new text

Blue: (if crossed out): text to be deleted

it results from Europeanian regulations

Component	Code no.	Irregularities/Criteria/Notes	Action to be taken	Irregularity class
Flange	1.4			
	1.4.1	Height of flange S_h greater than 36 mm <ul style="list-style-type: none"> hollow on wheel tread <p>Wagon with LL brake blocks and permissible speed greater than 100 km/h</p>	Detach wagon	4
	1.4.2	Height of wheel flange S_h greater than 32 mm <ul style="list-style-type: none"> Hollow on wheel tread włębienia na powierzchni tocznej <p>Flange thickness S_d</p> <ul style="list-style-type: none"> wheel $\varnothing > 840$ mm $S_d < 22$ mm wheel \varnothing: 630 (330) mm 760 mm $\leq d \leq 840$ mm, $S_d <$27.5 25 mm wheel $\varnothing \leq 760$ mm, $S_d < 27.5$ mm wheel $\varnothing > 330$ mm on wagons with LL or K brake blocks $S_d > 33$ mm 	Detach wagon	5
	1.4.3	worn flange <i>ostre obrzeże</i> Wear of guide laces <ul style="list-style-type: none"> $qR \leq 6.5$ mm (see Annex 4) sharp flange 	Detach wagon	5

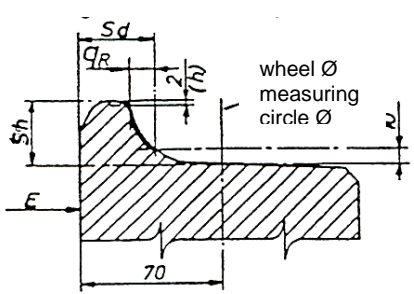
	1.4.4	<p>Burrs or sharp edges on guide face at a distance $h > 2$ mm from maximum height of flange (see also Annex 4)</p> 	Detach wagon	5
--	-------	---	--------------	---

4. Reason:

The requirements of the Usage Guidelines for Composite (LL) Brake Blocks (tenth edition) in relation to the wheel flange height for vehicles with maximum speeds of more than 100 km/h are applied.

“2.2.3 Monitoring of wheel profiles (running characteristics)”

Based on the results of UIC B 126 / RP 43, the following recommendations are given for the composite (LL) brake block system. In the light of specific experience and where justified by a corresponding risk assessment, the ECM2 may adapt the requirements.

2.2.3.1 General requirements (mandatory):

1. The equivalent conicity (a relevant parameter for the wheel/rail contact conditions) shall not exceed the value of 0.40₃.
2. The wheel profiles shall be monitored at regular intervals.

2.2.3.2 One way to ensure the fulfilment of the requirements of section 2.2.3.1 is to apply the following measures:

1. A reduced nominal flange thickness of less than or equal to 30.5 mm (wheel profile as per EN 13715 - S1002) shall be used.
2. If using wheels with low flange thickness (see point 1), as an alternative to determining the equivalent conicity, a reduced in-service flange height limit value of 32 mm and an inspection flange height limit value of 31 mm may be used.
3. The first inspection following reprofiling shall take place after 100,000 km and thereafter every 50,000 km.
4. If the LL blocks are retrofitted to non-reprofiled wheels, the first inspection shall be conducted directly after retrofitting. The equivalent conicity value or the alternative parameter of flange height shall comply with the requirements mentioned above (points 1 to 3). The next inspection shall take place after 50,000 km and thereafter every 50,000 km.

If higher nominal flange thicknesses or different wheel profiles are used, shorter inspection intervals need to be applied depending on the ECM risk assessment.

2.2.3.3 If nominal flange thicknesses of less than or equal to 30.5 mm (wheel profile as per EN 13715 - S1002) are used, the two options hereafters offer a way to adapt the general requirements, under the responsibility of the ECM4:

1. To be able to run wagons without monitoring of the wheel profile defined in section 2.2.3.1, their maximum operational speed of the wagon type shall be limited to 100 km/h. This is only applicable for wagons with running gear capable of a maximum operational speed of 120 km/h.

or

2. If the wagons' wheel profiles are to be monitored less rigorously, the wagons' running behaviour shall be verified against EN 14363 / UIC Leaflet 518, using wheelsets with an equivalent conicity higher than 0.405. This verification shall demonstrate the wagons' compliance with the safety provisions of the standard/leaflet.

Monitoring of wheel profile following operational irregularities:

- Following locked brake incidents in service, either the equivalent conicity value or the alternative parameter of flange height shall be verified."

In addition, account must be taken of the modification of wear conditions on the wheel profile for wheelsets with composite brake blocks. A reduced nominal flange thickness, less than or equal to 30.5 mm, has also been introduced for composite brake blocks (see the Design Rules for K Brake Blocks (UIC) and the Usage Guidelines for LL Brake Blocks (UIC)). There is a greater likelihood of wheel flanges increasing on wheels with composite brake blocks than there is on wheels with cast-iron brake blocks. The upper limit of 33 mm must also be verified in order to avoid exceeding the maximum wheel flange thickness (EN 15313).

5. Assess potential positive/negative impacts

E.g. on operations, costs, administration, interoperability, safety, competitiveness, etc., using a scale of 1 (very low) to 5 (very high).

Justify observations

Impacts:

Operations: 4

Interoperability: 1

Competitiveness: 1

Costs: 5 (exorbitant maintenance costs in the event of an overly severe assessment of damages)

Administration: 4

Safety (grade 4)

6. Safety appraisal of proposed amendment

Description of actual/target system, and scope of change to be made (see points 1 and 2).

The risk study becomes obsolete insofar as only the known repositories are implemented

Safety study conducted by:

6.1. Does the change make impact on safety?	<input type="checkbox"/> No <input checked="" type="checkbox"/> Yes
Reason: Implementation of the specifications for the size limit for wheel flange height on wheelsets of vehicles with LL brake blocks and a maximum speed > 100 km/h. Implementation of the specifications for the size limit for wheel flange thickness on wheelsets of vehicles with LL and K brake blocks.	
6.2. Is the change significant?	<input checked="" type="checkbox"/> No <input type="checkbox"/> Yes
Reason: Level of innovation: high. These omissions have not been taken into account until now. The new operating limits have to be taken into account. Level of complexity: low. Few interfaces with other subsystems and persons concerned. Consequences of failure: minor. The modified operating limits have not yet been processed. Monitoring: high level of monitoring. On account of the quality management system within the GCU. Reversibility: reversible. The code may be deleted when the document is updated.	
6.3. Determining and classifying risk:	<input checked="" type="checkbox"/> deleted
6.3.1. Effect of change in normal operation: 6.3.2. Effect of change in the event of disruption / deviation from normal operation: 6.3.3. Potential misuse of system: <input type="checkbox"/> No <input type="checkbox"/> Yes (describe possible misuse):	
6.4. Have safety measures been applied?	<input checked="" type="checkbox"/> No <input type="checkbox"/> Yes
For each type of risk, one of the following risk acceptance criteria is to be selected: <ul style="list-style-type: none"> • “Code of practice” (acknowledged technical rules) • Use of reference system • Explicit risk estimate 	
6.5. Has a risk analysis been submitted to the assessment body?	<input checked="" type="checkbox"/> No <input type="checkbox"/> Yes
Assessment body: Attach the verdict reached by the assessment body:	[appendix]